



Vertex Water Features

Lake Aeration Systems & Floating Fountains

With
Vertex
MicronBubble™
Technology

B O T T O M A E R A T I O N



AIR 1 PLUS™

The Vertex Air 1 Plus™ is an inexpensive solution for small, 1-2 acre ponds with irregular shapes and depths that impede normal diffuser circulation. The Air 1 Plus™ has the same powerful compressor system and cabinet as our standard Air 1 system but includes a valve manifold and second CoActive AirStation™ for extra circulation. This additional AirStation™ can be placed in cove areas, finger canals, behind shallow sandbars or anywhere in the water body where the pond's shape or bottom contour will limit oxygen flow from a single diffuser.

The Air 1 Plus™ utilizes Vertex's MicronBubble™ technology allowing vital oxygen to be absorbed and poisonous gasses expelled. With no electricity in the water, Vertex's aeration systems are safe for any type of water recreation. Our systems have an industry leading two-year warranty plus a five-year warranty against rust and corrosion on the cabinet, five-year warranty on the AirStations™ and a 15-year warranty on BottomLine™ supply tubing.

FEATURES

COACTIVE AIRSTATION™

- ◆ Independently tested pumping rate, up to 7,872 GPM
- ◆ Four 9" flexible membrane discs with MicronBubble™ technology
- ◆ Self-cleaning, low maintenance & 5 year warranty
- ◆ Rugged EPDM construction
- ◆ Vacuum formed and sonic welded HDPE base unit
- ◆ Lipped edge prevents sinking into soft bottom sediments
- ◆ Five-year warranty

BROOKWOOD™ COMPRESSOR

- ◆ Two-year Vertex warranty
- ◆ Vertex SafeStart™ Technology
- ◆ U.L., 115 volt, 30 PSI
- ◆ Thermal overload protection
- ◆ 1/3 hp for low electrical costs
- ◆ 2-3 year extended duty cycle between scheduled maintenance

QUIETAIR™ AIR 1 PLUS CABINET

- ◆ Class "A" GFCI protection on all circuits
- ◆ Powder coated aluminum for a durable attractive finish
- ◆ High capacity 140 CFM fan
- ◆ Easy access design with barrel lock for security
- ◆ Easy plug-in connection to waterside electrical service
- ◆ Heavy duty mounting pad included
- ◆ 5-year warranty

BOTTOMLINE™ TUBING

- ◆ Over-sized 0.58" ID for high flow
- ◆ Heavy duty wall thickness for durability
- ◆ Self-weighted for easy installation
- ◆ Available in 100 and 500 feet increments
- ◆ 15-year Vertex warranty

BENEFITS TO THE LAKE

- ◆ High, independently tested pumping rate
- ◆ Entire water column circulated
- ◆ Increased oxygen levels throughout water column
- ◆ Elimination of low oxygen fish kills
- ◆ Reduced nutrient levels and associated algae growth
- ◆ Oxidized/reduced bottom muck
- ◆ Improved fisheries by expanding oxygenated habitat
- ◆ Reduced aquatic midge and mosquito insect hatches
- ◆ Elimination of foul odors from undesirable dissolved gasses
- ◆ Safe entry - no electricity in the water
- ◆ Extended warranties on all system components

SPECIFICATIONS: AIR 1 PLUS™ LAKE AERATION SYSTEM

BROOKWOOD™ COMPRESSOR

1/3hp, 115v, Single Phase piston type compressor. Built for continuous 24/7 operation and equipped with Vertex SafeStart™ technology allowing auto restart under maximum rated pressure without motor damage. Super-duty Brookwood™ compressors incorporate upgraded rotors, stators, valve plates, bearings and capacitors and are thermally protected, oil-free, and require no lubrication; just periodic cleaning of included washable air filter. Extended duty cycle is approximately 24 to 36 months for compressor maintenance, about 2 to 3 times the duty cycle of ordinary piston and rotary vane compressors. All Brookwood™ SafeStart™ compressors carry a two year warranty.

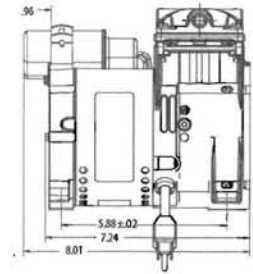

QUIETAIR™ AIR 1 PLUS CABINET

Cabinet is constructed of aluminum with gray electrostatically bonded powder coating. Equipped with a stamped ventilation grill, engineered fan plenum, directed exhaust and an integral cooling fan producing 140 CFM to guard against excessive compressor operating temperatures. Cabinet comes equipped with Class "A" GFCI Protection on both the compressor and fan circuits. Two-year warranty on all cabinet components including compressor, cooling fan and GFI and a five-year warranty against cabinet rust and corrosion.

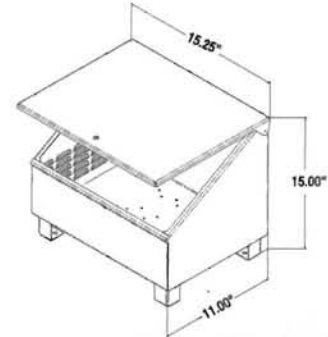

CoACTIVE™ AIRSTATION™

Each CoActive AirStation™ consists of two self-cleaning, 9" diameter flexible membrane diffusers of EPDM compound with 100% rebound memory, each producing millions of fine 500 to 3000 micron bubbles. Each diffuser station is equipped with a vacuum-formed HDPE base; sonic spot-welded to provide unit integrity. Base unit (17.25"L x 13.25"W x 3.35"D) has a hollow chamber design for the addition of gravel ballast and a lipped design to prevent settling into soft bottom sediments. AirStations have been independently tested and verified to provide stated pumping rates. Five year warranty.

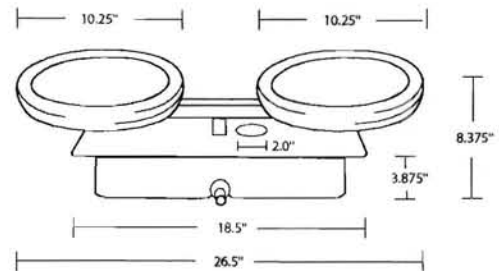

BOTTOMLINE™ SUPPLY TUBING

Self-weighted, direct burial submersible tubing for connection from compressor to diffuser stations. Tubing is flexible PVC composite construction for use with standard PVC solvent weld cement and 0.5" insert fittings. Tubing has a smooth walled, 0.58" I.D. for extra high flow rates with minimum friction loss to reduce backpressure and extend compressor life. 0.235" tube wall thickness provides long-term durability and protection against kinking and punctures. BottomLine™ tubing remains flexible in cold temperatures allowing for easy year round installations.

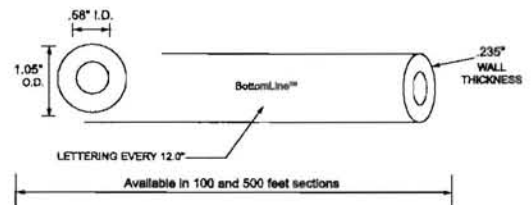

(800) 432-4302 / Fax (954) 977-7877
www.vertexwaterfeatures.com / e-mail: info@vertexwaterfeatures.com

Install all electrical equipment in accordance with Article 680 of the National Electrical Code and all local codes. Vertex Water Features reserves the right to improve and change our designs and/or specifications of our aerators without notice or obligation.
© 2007 Vertex Water Features



DURABLE

- ◆ Heavy duty aluminum construction.
- ◆ Gray powdercoated finish for maximum corrosion protection.
- ◆ Fully gasketed seals for quiet operation and protection from external moisture.

SAFE

- ◆ Equipped with a **Class A GFCI** on both the compressor and fan circuit for protection from electrical shock.
- ◆ Secure chrome plated barrel lock with an integral weather cover to prevent unauthorized access.

ECONOMICAL

- ◆ Lifetime warranty against destructive rust — save money on future replacement costs.
- ◆ Oversized 235 CFM cooling fan and a forced ventilation design for longer compressor life.
- ◆ Pigtail included for easy electrical connection to lakeside receptacle.

QUIETAIR™ CABINETS

BUILT BETTER THAN THEY NEED TO BE!



VERTEX
QUIETAIR™
CABINETS —
SUPERIOR IN
CONSTRUCTION

New QuietAir™ compressor cabinets are the latest addition to the quality line of superior lake aeration products offered by Vertex Water Features™. Designed from the ground up to provide you, our customer, the finest quality product available anywhere in the industry, QuietAir™ cabinets offer advantages and benefits unseen before in lake aeration technology.

Lake management professionals, golf course superintendents, parks and recreation directors — all those familiar with alternative models will find that the QuietAir™ offers outstanding quality and dependability!

COMPARE VERTEX QUIETAIR™ FEATURES

- ◆ **Aluminum Construction:** Welded, reinforced, heavy duty aluminum — no more rusted, unsightly steel cabinets!
- ◆ **Powdercoated Finish:** Long-lasting, electronically bonded powder coating offers additional protection from corrosion.
- ◆ **Cooler Operation:** With our 235 CFM cooling fans and forced ventilation design, compressors run cooler — promoting longer service life.
- ◆ **Safer Operation:** All QuietAir™ cabinets are equipped with CLASS A ground fault protection on both the compressor and cooling fan to provide the most sensitive protection from hazardous electrical shock.
- ◆ **Quiet Operation:** Each cabinet is equipped with fully gasketed seals to provide for quiet running and protection from moisture intrusion at no extra cost.
- ◆ **Security:** Chrome plated barrel lock provides protection from vandalism and unauthorized access. Includes integral weather tight cover to keep out dirt and moisture.
- ◆ **Easy Access Cover:** Fast, easy access to cabinet components provided by the QuietAir™ angled, oversized opening design.
- ◆ **Warranty:** Lifetime warranty against rust.



Vertex Water Features

Floating Fountains & Lake Aeration Systems

B O T T O M A E R A T I O N S Y S T E M S

WHY USE BOTTOMLINE™ TUBING?

DURABILITY!

- ◆ Rugged PVC composite extrusion.
- ◆ Heavy duty 1/4" thick walls.
- ◆ Impervious to fish hooks and extreme weather conditions.

WORKABILITY!

- ◆ Specifically formulated to remain flexible during cold weather conditions.
- ◆ Self-weighted for quick and easy installations.
- ◆ Totally kink-proof.
- ◆ Uses common PVC insert fittings.

LESS EXPENSIVE!

- ◆ **Money:** Costs less than lead keeled or other PVC tubing.
- ◆ **Time:** Installation times are a fraction of poly tubing.

NEW TUBING MAKES WAVES! BOTTOMLINE™ TUBING

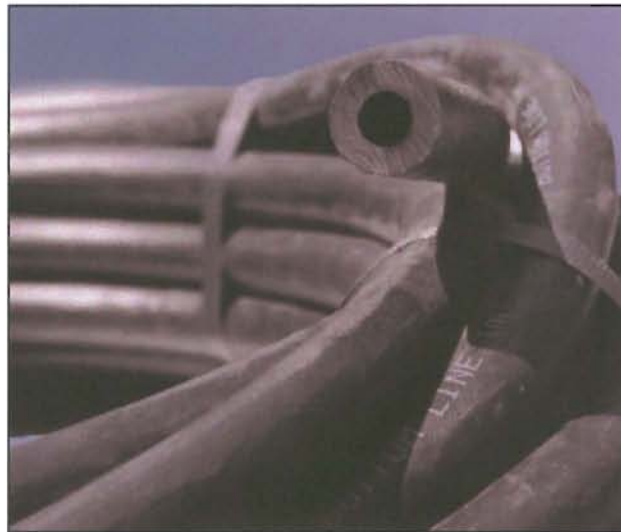

VERTEX BOTTOMLINE TUBING IS EASY-TO-USE FOR QUICK INSTALLATIONS.

BottomLine™ self-weighted air supply tubing has made quite an impression in the aeration industry. By addressing the needs of professionals in the lake management, golf course and parks and recreation industries, Vertex Water Features has developed the perfect airline supply tubing for lake aeration systems ... *and that's the Vertex BottomLine™!*

COMPARE VERTEX BOTTOMLINE™ FEATURES

- ◆ **Unweighted poly tubing:** Extremely labor intensive installation, bricks must be added for weight every few feet, thin walls cause frequent kinking and are easily punctured by fishhooks and wildlife.
- ◆ **Lead keeled poly tubing:** has same thin wall problems as poly tubing plus highest costs and introduces potentially dangerous lead into the ecosystem.
- ◆ **Other PVC tubing:** is stiff to begin with and becomes more rigid in cooler temperatures making installations more difficult and labor intensive.
- ◆ **Vertex Bottomline tubing:** The professional's choice providing the desired flexibility and durability with easy installation — all at a reasonable cost!

Contact us today for a free site analysis, a recommendation and the location of a distributor near you ... 800-432-4302.